



itl boulder

THE LIGHT CENTER OF THE INDUSTRY SINCE 1955

INDEPENDENT TESTING LABORATORIES, INC.
3386 LONGHORN ROAD, BOULDER, CO 80302 USA

PHONE: (303)442-1255 • FAX: (303)449-5274 • E-MAIL: itl@itlboulder.com • WEBSITE: www.itlboulder.com

REPORT NUMBER: ITL62870

DATE: 08/05/09

PREPARED FOR: NEXXUS LIGHTING, INC.

CATALOG NUMBER: ADCMR16WW60

LAMP: ONE MR-16 STYLE BI-PIN BASE LED LAMP, MOLDED FINNED WHITE PLASTIC BODY, ONE WHITE CIRCUIT BOARD WITH 39 VERTICAL BASE-UP WHITE LIGHT EMITTING DIODES (LEDS), MULTIPLE METAL POSTS BETWEEN UPPER AND LOWER HOUSING, FROSTED FLAT PLASTIC LENS, VERTICAL BASE-UP POSITION.

TOTAL INPUT WATTS = 3.14 AT 12.0 VOLTS DC

NOTE: DATA SHOWN IS ABSOLUTE FOR THE SAMPLE PROVIDED AT RATED INPUT VOLTAGE (12VDC) TO THE LAMP.

TEST PROCEDURE: IESNA LM-79-08

TEST DISTANCE = 25.25 FEET

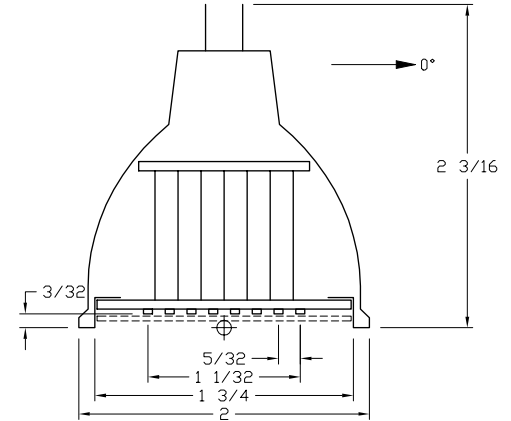

DEG	CANDELA	LUMENS
0	67.0	
5	66.8	6.4
15	64.5	18.2
25	59.7	27.5
35	52.5	32.8
45	42.8	33.0
55	31.6	28.3
65	20.1	19.9
75	9.6	10.1
85	1.3	1.7
90	0.0	

ZONAL LUMEN SUMMARY

ZONE	LUMENS	%FIXT
0- 30	52.1	29.3
0- 40	84.9	47.7
0- 60	146.2	82.2
0- 90	177.9	100.0
90-180	0.0	0.0
0-180	177.9	100.0

EFFICACY = 56.7 Lm/W

CIE TYPE - DIRECT

LUMINAIRE SPACING CRITERION = 1.2

LUMINOUS DIAMETER: 1.750

LUMINANCE DATA IN CANDELA/SQ M

ANGLE AVERAGE

IN DEG

45	38991.
55	35490.
65	30638.
75	23894.
85	9609.

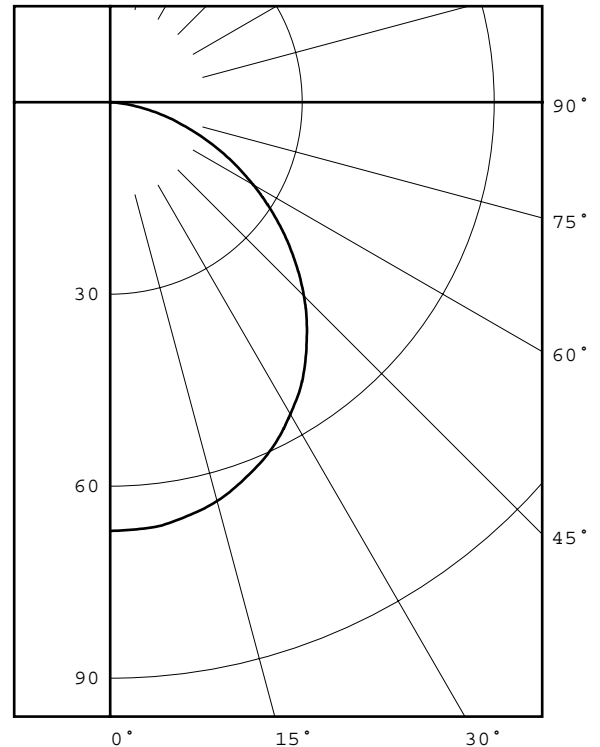

Checked N. WHITE

Approved R. BEATTIE



INDEPENDENT TESTING LABORATORIES, INC.
 3386 LONGHORN ROAD, BOULDER, CO 80302 USA

PHONE: (303)442-1255 • FAX: (303)449-5274 • E-MAIL: itl@itlboulder.com • WEBSITE: www.itlboulder.com

REPORT NUMBER: ITL62870
 PREPARED FOR: NEXXUS LIGHTING, INC.

DATE: 08/05/09

CANDELA DISTRIBUTION

	0.0
0.0	67.0
2.5	66.9
5.0	66.8
7.5	66.5
10.0	65.9
12.5	65.3
15.0	64.5
17.5	63.5
20.0	62.3
22.5	61.1
25.0	59.7
27.5	58.1
30.0	56.3
32.5	54.5
35.0	52.5
37.5	50.2
40.0	47.8
42.5	45.4
45.0	42.8
47.5	40.1
50.0	37.3
52.5	34.5
55.0	31.6
57.5	28.7
60.0	25.8
62.5	22.9
65.0	20.1
67.5	17.3
70.0	14.6
72.5	11.9
75.0	9.6
77.5	7.2
80.0	5.0
82.5	2.9
85.0	1.3
87.5	0.3
90.0	0.0

ZONAL LUMEN SUMMARY

0- 5	2.
5- 10	5.
10- 15	8.
15- 20	10.
20- 25	13.
25- 30	15.
30- 35	16.
35- 40	17.
40- 45	17.
45- 50	16.
50- 55	15.
55- 60	13.
60- 65	11.
65- 70	9.
70- 75	6.
75- 80	4.
80- 85	2.
85- 90	0.



INDEPENDENT TESTING LABORATORIES, INC.
 3386 LONGHORN ROAD, BOULDER, CO 80302 USA

PHONE: (303)442-1255 • FAX: (303)449-5274 • E-MAIL: itl@itlboulder.com • WEBSITE: www.itlboulder.com

REPORT NUMBER: ITL62870

DATE: 08/05/09

PREPARED FOR: NEXXUS LIGHTING, INC.

COEFFICIENTS OF UTILIZATION - ZONAL CAVITY METHOD

EFFECTIVE FLOOR CAVITY REFLECTANCE 0.20

RC	80				70				50			30			10			0
RW	70	50	30	10	70	50	30	10	50	30	10	50	30	10	50	30	10	0
0	119	119	119	119	116	116	116	116	111	111	111	106	106	106	102	102	102	100
1	109	105	101	97	107	103	99	96	98	95	93	95	92	90	91	89	87	85
2	100	92	85	80	97	90	84	79	87	81	77	83	79	75	80	77	74	72
3	91	81	73	67	89	79	72	66	76	70	65	74	68	64	71	67	63	61
4	84	72	63	57	81	71	63	56	68	61	56	66	60	55	64	58	54	52
5	77	64	56	49	75	63	55	49	61	54	48	59	53	48	57	52	47	45
6	71	58	49	43	69	57	49	43	55	48	42	54	47	42	52	46	42	40
7	66	53	44	38	64	52	44	38	50	43	38	49	42	37	48	42	37	35
8	61	48	40	34	60	47	39	34	46	39	34	45	38	33	44	38	33	31
9	57	44	36	31	56	44	36	30	42	35	30	41	35	30	40	34	30	28
10	54	41	33	28	53	40	33	28	39	32	28	38	32	27	37	32	27	26

ALL CANDELA, LUMENS, LUMINANCE, AND VCP VALUES IN THIS REPORT ARE BASED ON ABSOLUTE PHOTOMETRY. THE COEFFICIENT OF UTILIZATION VALUES ARE BASED ON THE TOTAL ABSOLUTE LUMEN OUTPUT OF THIS LUMINAIRE SAMPLE.

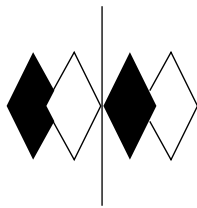

itl boulder

THE LIGHT CENTER OF THE INDUSTRY SINCE 1955

INDEPENDENT TESTING LABORATORIES, INC.
3386 LONGHORN ROAD, BOULDER, CO 80302 USA

PHONE: (303)442-1255 • FAX: (303)449-5274 • E-MAIL: itl@itlboulder.com • WEBSITE: www.itlboulder.com

REPORT NUMBER: ITL62881 Page 1 of 1
DATE: 8/05/09
PREPARED FOR: NEXXUS LIGHTING, INC.

CATALOG NUMBER: ADCMR16WW60

LAMP: ONE MR-16 STYLE BI-PIN BASE LED LAMP, MOLDED FINNED WHITE PLASTIC BODY, ONE WHITE CIRCUIT BOARD WITH 39 VERTICAL BASE-UP WHITE LIGHT EMITTING DIODES (LEDS), MULTIPLE METAL POSTS BETWEEN UPPER AND LOWER HOUSING, FROSTED FLAT PLASTIC LENS, VERTICAL BASE-UP POSITION.

NOTE: DATA SHOWN IS ABSOLUTE FOR THE SAMPLE PROVIDED AT RATED INPUT VOLTAGE (12VDC) TO THE LAMP.

INSTRUMENTATION: BK Precision 1745A DC Power Supply
Yokogawa WT210 Digital Power Meter
Optronics OL770 Spectroradiometer
ITL 1.5 Meter Diameter Integrating Sphere

OBJECT OF TEST: Measure the Correlated Color Temperature (CCT), Color Rendering Index (CRI), Chromaticity Coordinates (x,y), ANSI C78.377 Duv, and input electrical parameters.

PROCEDURE: The lamp was provided by customer and the LEDs had an unknown number of burn hours. The lamp was mounted inside the integrating sphere with the lamp in a base up position (LEDS facing down). The lamp was allowed to stabilize at 12 VDC input. After stabilization occurred, CCT, CRI, x/y chromaticity coordinates, ANSI C78.377 Duv, and input electrical data were measured with the lamp operating in the integrating sphere. In order to measure the mean performance, twenty data sets were recorded and averaged within the OL770. Readings were taken with the lamp operating at 12 VDC input in a 25 +/-1 degree Celsius free air ambient and in accordance with IESNA LM-79-08. All data are traceable to the National Institute of Standards and Technology.

RESULTS:

SPECTRORADIOMETRIC	
Observer	CIE 1931 2 degree
Correlated Color Temp CCT (K)	3011
Chromaticity Ordinate x	0.4402
Chromaticity Ordinate y	0.4122
Color Rendering Index (CRI)	76
ANSI C78.377-2008 Duv	0.003
ELECTRICAL	
Input Voltage (Volts DC)	12.0
Input Current (mA DC)	258
Input Power (Watts)	3.10

Checked: <u>N Gully</u>
Approved: <u>R Bergin</u>